

SPECIAL MEETING – TUESDAY, August 25, 2020

On this the 25th day of August, 2020 at 9:00 A.M. the Honorable Commissioners Court of Blanco County convened in a SPECIAL MEETING at a regular meeting place thereof in the Courthouse in Johnson City with the following members to-wit:

BRETT BRAY	COUNTY JUDGE
TOMMY WEIR	COMMISSIONER PCT. 1
EMIL UECKER	COMMISSIONER PCT. 2
CHRIS LIESMANN	COMMISSIONER PCT. 3
PAUL GRANBERG	COMMISSIONER PCT. 4
LAURA WALLA	COUNTY CLERK

ITEM 1 – Call to Order and Roll Call.

Judge and all 4 County Commissioners announced present.

ITEM 2 – Pledge of Allegiance.

Public Hearing on Proposed Budget

ITEM 3 – The general public and any other interested parties or person are invited to attend make comments regarding the Proposed Budget for FY 2020-21.

ITEM 4 – Discussion of the Proposed Budget for FY 2020-21.

Public Hearing on Proposed Tax Rate

ITEM 5 – The general public and any other interested parties or person are invited to attend and make comments regarding the Proposed Property Tax Rate for FY 2020-21.

ITEM 6 – Discussion of the Proposed Property Tax Rate for FY 2020-21.

Return to Special Meeting

ITEM 7 – PUBLIC COMMENTS – opportunity for the general public to address the Court on any matter. Comments are limited to 3 minutes.

ITEM 8 – Consider approval of minutes of prior Commissioners Court meeting(s). Vote on any action taken. (Judge Bray)

COMMISSIONER WEIR made the motion to dispense with the reading of the minutes and to approve as presented, seconded by Commissioner Uecker. Judge Bray called for discussion and vote.

JUDGE BRAY – YES.

COMMISSIONER WEIR – YES.

COMMISSIONER UECKER – YES.

COMMISSIONER LIESMANN – YES.

COMMISSIONER GRANBERG – YES. MOTION CARRIED. 5/0

ITEM 9 – Consider ratifying or approving line item transfers as presented. Vote on any action taken. (Judge Bray)

COMMISSIONER LIESMANN made the motion approving the line item transfers as presented, seconded by Commissioner Granberg. Judge Bray called for discussion and vote.

JUDGE BRAY – YES.

COMMISSIONER WEIR – YES.

COMMISSIONER UECKER – YES.

COMMISSIONER LIESMANN – YES.

COMMISSIONER GRANBERG – YES. MOTION CARRIED. 5/0

ITEM 10 – Consider approval of the outstanding bills. Vote on any action taken. (Judge Bray)

COMMISSIONER LIESMANN made the motion approving the outstanding bills in the amount of \$126,476.89, seconded by Commissioner Uecker. Judge Bray called for discussion and vote.

JUDGE BRAY – YES.

COMMISSIONER WEIR – YES.

COMMISSIONER UECKER – YES.

COMMISSIONER LIESMANN – YES.

COMMISSIONER GRANBERG – YES. MOTION CARRIED. 5/0

ITEM 11 – Consider authorization for the County Judge to renew the Interlocal agreement with Texas Parks & Wildlife to continue processing boat motor registrations. Vote on any action taken. (TAC Spies)

COMMISSIONER LIESMANN made the motion authorizing the County Judge to renew the Interlocal agreement with Texas Parks & Wildlife to continue processing motor boat registrations, seconded by Commissioner Granberg. Judge Bray called for discussion and vote.

JUDGE BRAY – YES.

COMMISSIONER WEIR – YES.

COMMISSIONER UECKER – YES.

COMMISSIONER LIESMANN – YES.

COMMISSIONER GRANBERG – YES. MOTION CARRIED. 5/0

ITEM 12 – Consider authorization for the County Judge to enter into an Interlocal cooperation agreement for prisoner housing with Mason County. Vote on any action taken. (Sheriff Jackson)

COMMISSIONER WEIR made the motion authorizing the County Judge to enter into an Interlocal cooperation agreement for prisoner housing with Mason County, seconded by Commissioner Uecker. Judge Bray called for discussion and vote.

JUDGE BRAY – YES.

COMMISSIONER WEIR – YES.

COMMISSIONER UECKER – YES.

COMMISSIONER LIESMANN – YES.

COMMISSIONER GRANBERG – YES. MOTION CARRIED. 5/0

ITEM 13 – Authorize the County Judge to sign the memorandum of understanding and multidisciplinary team working protocols with Hill Country Children’s Advocacy Center. Vote on any action taken. (Sheriff Jackson)

COMMISSIONER LIESMANN made the motion authorizing the County Judge to sign the memorandum of understanding and multidisciplinary team working protocols with Hill County Children’s Advocacy Center, seconded by Commissioner Granberg. Judge Bray called for discussion and vote.

JUDGE BRAY – YES.

COMMISSIONER WEIR – YES.

COMMISSIONER UECKER – YES.

COMMISSIONER LIESMANN – YES.

COMMISSIONER GRANBERG – YES. MOTION CARRIED. 5/0

ITEM 14 – Authorize the County Judge to sign a contract with D.A.D. Services Inc. to retrofit or replace the septic system at 2032 Trainer Wuest Road relocation. Vote on any action taken. (Commissioner Weir)

COMMISSIONER WEIR made the motion authorizing the County Judge to sign a contract with D.A.D. Services, Inc., to retrofit or replace the septic system at 2032 Trainer Wuest Road relocation, seconded by Commissioner Uecker. Judge Bray called for discussion and vote.

JUDGE BRAY – YES.

COMMISSIONER WEIR – YES.

COMMISSIONER UECKER – YES.

COMMISSIONER LIESMANN – YES.

COMMISSIONER GRANBERG – YES. MOTION CARRIED. 5/0

ITEM 15 – Authorization to advertise for bids for a new or used distributor truck for Precinct 3. Vote on any action taken. (Commissioner Liesmann)

COMMISSIONER LIESMANN made the motion authorizing to advertise for bids for a new or used distributor truck for Precinct 3 with bids being due October 13, 2020, seconded by Commissioner Weir. Judge Bray called for discussion and vote.

JUDGE BRAY – YES.
COMMISSIONER WEIR – YES.
COMMISSIONER UECKER – YES.
COMMISSIONER LIESMANN – YES.
COMMISSIONER GRANBERG – YES. MOTION CARRIED. 5/0

ITEM 16 – Consider approval to pay Ruvalcabas Paving Co. invoice in the amount of \$50,000 for the Middle Creek Rd. paving project. Funds to be paid from special road and bridge account. Vote on any action taken. (Commissioner Granberg)

COMMISSIONER GRANBERG moved to approve to pay Ruvalcabas Paving Co. invoice in the amount of \$50,000 for the Middle Creek Rd. paving project with funds to be paid from special road and bridge account, seconded by Commissioner Weir. Judge Bray called for discussion and vote.

JUDGE BRAY – YES.
COMMISSIONER WEIR – YES.
COMMISSIONER UECKER – YES.
COMMISSIONER LIESMANN – YES.
COMMISSIONER GRANBERG – YES. MOTION CARRIED. 5/0

ITEM 17 – The Blanco County Democratic Party request the approval to replace Precinct 102 alternate judge, Nova (Claire) Phillips with Lorraine Tingler and Precinct 401 alternate judge, Suzanne Perkins with Nova (Claire) Phillips to complete the two-year term ending August 31, 2021. Vote on any action taken.

COMMISSIONER WEIR made the motion approving the Blanco County Democratic Party request for the approval to replace Precinct 102 alternate judge, Nova (Claire) Phillips with Lorraine Tingler and Precinct 401 alternate judge, Suzanne Perkins with Nova (Claire) Phillips to complete the two-year term ending August 31, 2021 and seconded by Commissioner Granberg. Judge Bray called for discussion and vote.

JUDGE BRAY – YES.
COMMISSIONER WEIR – YES.
COMMISSIONER UECKER – YES.
COMMISSIONER LIESMANN – YES.
COMMISSIONER GRANBERG – YES. MOTION CARRIED. 5/0

ITEM 18 – Discussion and possible action to approve Order for Transferring Election Duties to County Tax Assessor-Collector. Vote on any action taken. (County Clerk Walla & TAC Spies)

COMMISSIONER WEIR made the motion approving the Order for Transferring Election Duties to County Tax Assessor-Collector, seconded by Commissioner Uecker. Judge Bray called for discussion and vote.

JUDGE BRAY – YES.
COMMISSIONER WEIR – YES.
COMMISSIONER UECKER – YES.
COMMISSIONER LIESMANN – YES.

COMMISSIONER GRANBERG – YES. MOTION CARRIED. 5/0

ITEM 19 – Consider on-going discussions regarding budget items for FY2020-21. Vote on any action taken. (Judge Bray)

ITEM 20 – Consider personnel policy change to replace current longevity pay for both part-time and full-time employees as follows:

- a. All employees shall be eligible for the longevity pay benefit.
- b. An employee shall be required to work a minimum of two (2) years before receiving longevity pay.
- c. Upon completion of the 2nd year of employment, an employee shall receive a one-time, three and three quarters percent (3.75%) salary increase over and above any annual increases granted by the Commissioners Court during their regular budget process. Upon completion of the 4th year of employment, an employee shall receive a one-time, two percent (2.00%) salary increase over and above any annual increases granted by the Commissioners Court during their regular budget process. Upon completion of the 6th year of employment and all subsequent years, an employee shall receive a one percent (1.00%) salary increase over and above any annual increases granted by the Commissioners Court during their regular budget process.
- d. Any employee that terminates employment with Blanco County and is subsequently rehired in the same or another position with the County shall begin the longevity process anew and shall lose any previous longevity that may have accrued.

Vote on any action taken. (Judge Bray)

COMMISSIONER LIESMANN made the motion to approve the personnel policy changes to replace the current longevity pay for both part time and full time employees as presented on the agenda, seconded by Commissioner Granberg. Judge called for discussion and vote.

JUDGE BRAY – YES.

COMMISSIONER WEIR – YES.

COMMISSIONER UECKER – YES.

COMMISSIONER LIESMANN – YES.

COMMISSIONER GRANBERG – YES. MOTION CARRIED. 5/0

ITEM 21 – Consider setting salaries for the elected officials for FY2020-21.

Elected Officials – full time	\$50,713
Elected Officials – part time (Constables 1 & 4)	\$25,791

Vote on any action taken. (Judge Bray)

COMMISSIONER GRANBERG moves that we consider salaries for the elected officials for FY2020-21 Elected Officials – full time, \$50,713, part time (Constables 1 & 4) \$25,791, seconded by Commissioner Weir. Judge Bray called for discussion and vote.

JUDGE BRAY – YES.

COMMISSIONER WEIR – YES.

COMMISSIONER UECKER – YES.
COMMISSIONER LIESMANN – YES.
COMMISSIONER GRANBERG – YES. MOTION CARRIED. 5/0

ITEM 22 – Consider setting base salaries for FY2020-21.

Secretary/Clerk/Deputy Clerk	
Road Technician/Maintenance (non LEC)	\$31,500
Chief Deputy Clerk	\$33,628
Chief Deputy	\$50,000
Deputy, Lieutenant	\$40,100
Deputy, Sergeant	\$42,000
Deputy	\$40,000
Dispatcher/Sergeant	\$36,500
Dispatcher	\$33,072
Investigator	\$42,000
Jailer, Lieutenant	\$38,325
Jailer, Sergeant	\$35,700
Jailer	\$33,503
Office Administrator	\$35,000
Maintenance @ LEC	\$33,503

Vote on any action taken. (Judge Bray)

COMMISSIONER WEIR made the motion setting the base salaries for FY2020-21 as recited in the agenda with the Lieutenant Dispatcher with a salary of \$38,325, seconded by Commissioner Uecker. COMMISSIONER WEIR wishes to amend his motion to include the Secretary/Clerk/Deputy Clerk with a salary of \$31,500, seconded by Commissioner Uecker. Judge Bray called for discussion and vote.

JUDGE BRAY – YES.
COMMISSIONER WEIR – YES.
COMMISSIONER UECKER – YES.
COMMISSIONER LIESMANN – YES.
COMMISSIONER GRANBERG – YES. MOTION CARRIED. 5/0

ITEM 23 – Consider adoption of the Blanco County budget for FY2020-21. Vote on any action taken. (Judge Bray)

COMMISSIONER LIESMANN made the motion to adopt the Blanco County budget for FY2020-21 as approved with the amendments done today, seconded by Commissioner Uecker. Judge Bray called for discussion and vote.

RECORD VOTES:

JUDGE BRAY – YES.
COMMISSIONER WEIR – YES.
COMMISSIONER UECKER – YES.

COMMISSIONER LIESMANN – YES.
COMMISSIONER GRANBERG – YES. MOTION CARRIED. 5/0

ITEM 24 – Consider adoption and setting the tax rate for FY2020-21 at \$0.3950.

- | | | |
|-------------------------------|---|----------|
| a. Maintenance and Operations | = | \$0.3550 |
| b. Debt Services (I&S) | = | \$0.0400 |

Vote on any action taken. (Judge Bray)

COMMISSIONER LIESMANN made the motion to adopt and set the tax rate for FY2020-21 for Maintenance and Operations at \$0.3500, seconded by Commissioner Granberg. Judge Bray called for discussion and vote.

RECORD VOTES:

JUDGE BRAY – YES.
COMMISSIONER WEIR – YES.
COMMISSIONER UECKER – YES.
COMMISSIONER LIESMANN – YES.
COMMISSIONER GRANBERG – YES. MOTION CARRIED. 5/0

COMMISSIONER LIESMANN made the motion to adopt and set the tax rate for FY 2020-21 for Debt Services (I&S) at \$0.0400, seconded by Commissioner Weir. Judge Bray called for discussion and vote.

RECORD VOTES:

JUDGE BRAY – YES.
COMMISSIONER WEIR – YES.
COMMISSIONER UECKER – YES.
COMMISSIONER LIESMANN – YES.
COMMISSIONER GRANBERG – YES. MOTION CARRIED. 5/0

ITEM 25 – Consider ratifying the tax increase of \$605,821 for FY2020-21. Vote on any action taken. (Judge Bray)

COMMISSIONER LIESMANN makes the motion to ratify the tax increase of \$526,487 in that amount \$284,385 is tax revenue based on new property added to the tax roll this year for the FY2020-21, seconded by Commissioner Uecker. Judge Bray called for discussion and vote.

RECORD VOTES:

JUDGE BRAY – YES.
COMMISSIONER WEIR – YES.
COMMISSIONER UECKER – YES.
COMMISSIONER LIESMANN – YES.
COMMISSIONER GRANBERG – YES. MOTION CARRIED. 5/0

ITEM 26 – Consider setting the homestead exemption at 1% of the appraised value with a minimum exemption of \$5000. Vote on any action taken. (Judge Bray)

COMMISSIONER WEIR made the motion to set the homestead exemption at 1% of the appraised value with a minimum of \$5000, seconded by Commissioner Granberg. Judge Bray called for discussion and vote.

RECORD VOTES:

JUDGE BRAY – YES.
COMMISSIONER WEIR – YES.
COMMISSIONER UECKER – YES.
COMMISSIONER LIESMANN – YES.
COMMISSIONER GRANBERG – YES. MOTION CARRIED. 5/0

ITEM 27 – Consider burn ban. Vote on any action taken. (Judge Bray)

ITEM PASSED AT THIS TIME.

ITEM 28 - Adjourn.

COMMISSIONER UECKER made the motion to adjourn, seconded by Commissioner Weir. Judge Bray called for discussion and vote.

JUDGE BRAY – YES.
COMMISSIONER WEIR – YES.
COMMISSIONER UECKER – YES.
COMMISSIONER LIESMANN – YES.
COMMISSIONER GRANBERG – YES. MOTION CARRIED. 5/0

Meeting adjourned at 10:00 a.m.

The above and foregoing minutes were examined and approved in Open Court this _____
day of _____, 2020.

I, Laura Walla, County Clerk, Blanco County, Texas attest that the foregoing is a true and correct accounting of the Commissioner’s Court authorized proceedings for August 25, 2020.

County Clerk and Ex-Officio Member of Commissioner’s Court, Blanco County, Texas

BLANCO COUNTY MONTHLY ESTIMATED PAYROLL APPROVAL FORM

SEPTEMBER 2020

	#10 General Fund	#15 Road & Bridge Fund	#18 Courthouse Security	Total
Salaries	\$199,455.00	\$22,961.74		\$222,416.74
Soc/Med	\$ 15,258.31	\$ 1,756.57		\$ 17,014.88
Retirement	\$ 16,275.53	\$ 1,873.68		\$ 18,149.21
Insurance	\$ 50,199.34	\$ 6,022.38		\$ 56,221.72
Group Term Life	\$ 398.86	\$ 9.38		\$ 408.24
Total	\$281,587.04	\$32,623.75		\$314,210.79

TOTAL PAYROLL TO BE APPROVED



 County Treasurer _____ Date 9-3-2020

County Judge _____ Date _____

COPY

Commissioner Pct 1 _____ Date _____

Commissioner Pct 2 _____ Date _____

Commissioner Pct 3 _____ Date _____

Commissioner Pct 4 _____ Date _____

Agenda
6

ALL Official
Reports are
IN

BLANCO COUNTY REQUEST FOR A LINE-ITEM TRANSFER

DATE: 9-3-2020

TO: HONORABLE COMMISSIONERS COURT OF BLANCO COUNTY, TEXAS

FROM: PAUL GRANBERG

DEPARTMENT General Budget

I SUBMIT TO YOU FOR YOUR CONSIDERATION, THE FOLLOWING LINE ITEM TRANSFERS:

	FUND	LINE ITEM	DESCRIPTION	LINE ITEM #	AMOUNT
FROM:	<u>AtB Pct 4</u>	<u>15-570-324</u>	<u>PAVING</u>	<u>324</u>	<u>\$42,650</u>

TO:	<u>AtB Pct 4</u>	<u>ROAD SIGNS / MARKERS</u>		<u>314</u>	<u>42,250</u>
					<u>\$</u>

Reason for request: DEPLETED LINE

Note: This change is the budget for county purposes is in accordance with 111.011 Changes in Budget for County Purposes" of the Local Government Code.

Paul Granberg
Department Head Signature

Attest: County Clerk
(if Commissioners' Court Action)

Brett B...
Co Judge/Commissioners' Court Approval
(as needed)

BLANCO COUNTY
REQUEST FOR A LINE-ITEM TRANSFER

9/3/20
Funds are available.

DATE: 9/2/2020

TO: HONORABLE COMMISSIONERS COURT OF BLANCO COUNTY, TEXAS

FROM: Commissioner Emil Uecker

DEPARTMENT Precinct 2

I SUBMIT TO YOU FOR YOUR CONSIDERATION, THE FOLLOWING LINE ITEM TRANSFERS:

FUND	LINE ITEM DESCRIPTION	LINE ITEM #	AMOUNT
FROM: <u>0322</u>	<u>concrete</u>	<u>15-550-322</u>	<u>11900.00</u>
	<u>contract labor</u>	<u>15-550-320</u>	<u>2000.00</u>
	<u>culverts & catchbasins</u>	<u>15-550-316</u>	<u>2000.00</u>

TO: Paving 15-550-324 5900.00

Reason for request: Purchase of material for preparing roads

Note: This change in the budget for county purposes is in accordance with 111.011 "Changes in Budget for County Purposes" of the Local Government Code.

Emil Uecker
Department Head Signature

Attest: County Clerk
(if Commissioners' Court Action)

Brett [Signature]
Co Judge/Commissioners' Court Approval
(as needed)

9/3/20

BLANCO COUNTY REQUEST FOR A LINE-ITEM TRANSFER

Funds are available

DATE: 9-2-2020

TO: HONORABLE COMMISSIONERS COURT OF BLANCO COUNTY, TEXAS

FROM: PAUL GRANBERG

DEPARTMENT General Budget

I SUBMIT TO YOU FOR YOUR CONSIDERATION, THE FOLLOWING LINE ITEM TRANSFERS:

FUND	LINE ITEM DESCRIPTION	LINE ITEM #	AMOUNT
FROM: R+B Pct 4	MISCELLANEOUS	15-570-310	\$500.00

TO: R+B Pct 4	PAVING	15-570-324	\$500.00
			\$ -

Reason for request: LANDSCAPE STONE FOR Pct 144 YARD

Note: This change is the budget for county purposes is in accordance with 111.011 Changes in Budget for County Purposes of the Local Government Code.

Paul Granberg Department Head Signature

Attest: County Clerk (if Commissioners' Court Action)

Co Judge/Commissioners' Court Approval (as needed)

Blanco County Commissioners' Court

September 8, 2020

Invoice File Listing By Fund

Fund	Description	Disbursement
010	General Fund	\$ 102,750.78
015	Road & Bridge Fund	\$ 27,961.83
019	Child Safety Fund	\$ 5,018.88
020	Records Management, District Crt	\$ 734.07
039	District Crt Tech Fund	\$ 1,000.00
046	Countywide Road & Bridge Improv	\$ 50,000.00
060	Interest & Sinking Fund	\$ 5,702.25
Total		\$ 193,167.81

The attached list of Claims Payable have been examined & approved for payment by the Assistant County Auditor as provided by the Texas LGC 113.064 & 113.065

Attest Asst. County Auditor: _____ Date: 9-3-2020

The attached list of Claims Payable have been examined & approved for payment by the Commissioners' Court as provided by the Texas LGC 115.021 & 115.022

County Judge _____ Date _____

Commissioner Pct 1 _____ Commissioner Pct 3 _____

Commissioner Pct 2 _____ Commissioner Pct 4 _____

DEPARTMENT	NAME-OF-VENDOR	INVOICE-NO	S	DESCRIPTION-OF-INVOICE	AMOUNT
0300-GENERAL FUND REVENUES					
	ADVANCE REPAIR SOLUTIONS	73866	A	REPAIRS OF MACK TRUCK	3,679.89
	DEPARTMENT TOTAL				3,679.89
0400-COUNTY JUDGE EXPENSES					
	CARD SERVICE CENTER	73956	A	4707 1205 3610 0617 SWIFT	55.93
	DEPARTMENT TOTAL				55.93
0410-COUNTY CLERK					
	BUSINESS CENTER PRINT & OS	73872	A	INV#141483 CO CLERK	435.43
	CARD SERVICE CENTER	73947	A	4707 1205 3610 0377 JUDGE	87.00
	DEPARTMENT TOTAL				522.43
0411-ELECTIONS ADMINISTRATOR					
	FRANCIELA MARIN-SMITH	73848	A	EARLY VOTING	176.50
	REBECCA S. TAYLOR	73847	A	EARLY VOTING	55.00
	DEPARTMENT TOTAL				231.50
0412-DISTRICT CLERK					
	NORTHEAST TEXAS DATA CORP.	73911	A	INV#ND-001881	163.93
	DEPARTMENT TOTAL				163.93
0420-TAX ASSESSOR/COLLECTOR					
	BUSINESS CENTER PRINT & OS	73874	A	INV#139649S TAC	119.96
	DEPARTMENT TOTAL				119.96
0425-COUNTY SHERIFF					
	A T & T MOBILITY	73861	A	ACCT #287289997662 LEC	41.29
	AUTO CHLOR SERVICES, LLC	73822	A	INV #6365613 LEC	187.90
	BAYLOR SCOTT WHITE	73823	A	PATIENT #H7300175986400	351.34
	CARD SERVICE CENTER	73950	A	4707 1205 3610 0617 SWIFT	234.94
	CARD SERVICE CENTER	73951	A	4707 1205 3610 0617 SWIFT	76.85
	CARD SERVICE CENTER	73952	A	4707 1205 3610 0617 SWIFT	148.52
	CARD SERVICE CENTER	73953	A	4707 1205 3610 0617 SWIFT	295.00
	CARD SERVICE CENTER	73954	A	4707 1205 3610 0617 SWIFT	233.29
	CARD SERVICE CENTER	73955	A	4707 1205 3610 0617 SWIFT	901.16
	CITY OF JOHNSON CITY	73857	A	ACCT #24001-0010125500 LEC	471.73
	CITY OF JOHNSON CITY	73858	A	ACCT #24001-0010131600 LEC LOW	916.94
	CITY OF JOHNSON CITY	73859	A	ACCT #24001-0010131700 LEC HIGH	49.01
	CLAWA ENTERPIRSE, INC	73868	A	INV#235552 LEC	1,645.95
	EXPRESS AUTOMOTIVE SERVICE	73885	A	INV#3760314 LEC	62.05
	EXPRESS AUTOMOTIVE SERVICE	73886	A	INV#3760369 LEC	62.05
	FRONTIER COMMUNICATIONS	73831	A	830-868-7104 LEC	1,034.52
	FUELMAN	73943	A	FUEL - LEC	4,538.58
	GALLS, LLC	73889	A	INV#016248915 LEC	152.97
	GALLS, LLC	73890	A	INV#016285356 LEC	203.96
	GALLS, LLC	73891	A	INV#016314614 LEC	93.50
	JOHNSON CITY HYDRO GAS	73957	A	ACCT #2570 LEC	1,271.39
	OFFICESUPPLY.COM	73914	A	INV#4018817 LEC	79.92
	PERFORMANCE FOOD SERVICE	73919	A	INV#9986436 LEC	1,487.36
	PERFORMANCE FOOD SERVICE	73920	A	INV#9993834 LEC	1,048.44
	STEVEN A LOGSDON	73930	A	PRE-EMPLOYMENT EXAMS - BIBLE, R	175.00
	SYMBOLARTS	73931	A	ORDER#0281321-IN LEC	457.50
	TIME WARNER CABLE	73844	A	INV #0144399081520 LEC	580.00
	VERIZON WIRELESS	73862	A	ACCT #642256328-0001 LEC	742.93
	DEPARTMENT TOTAL				17,544.09
0432-COUNTY AUDITOR					

DEPARTMENT

NAME-OF-VENDOR	INVOICE-NO	S	DESCRIPTION-OF-INVOICE	AMOUNT
VERIZON WIRELESS	73845	A	ACCT #242014685-00001 AUDITOR	25.99
DEPARTMENT TOTAL				25.99
0435-INDIGENT HEALTH CARE				
MICHAEL W. MANN MD, PA	73837	A	PATIENT #004082020	46.73
MICHAEL W. MANN MD, PA	73838	A	PATIENT #004082020	46.73
SCOTT & WHITE HOSPITAL	73863	A	PATIENT #PH9490275922	54.41
DEPARTMENT TOTAL				147.87
0450-JUDICIAL EXPENSES				
BLANCO COUNTY DISTRICT CLERK	73825	A	GRAND JURY SEPTEMBER 10, 2020	480.00
CENTRAL TEXAS AUTOPSY PLLC	73827	A	INV #13189	2,100.00
CENTRAL TEXAS AUTOPSY PLLC	73828	A	INV #13192	2,100.00
NORTHEAST TEXAS DATA CORP.	73910	A	INV#ND-001881	1,800.00
SHELL & SHELL	73841	A	33RD CASE #CR01838	800.00
SHELL & SHELL	73850	A	424TH CASE #1818	425.00
STEVEN MICHAEL TODD	73842	A	33RD CASE #CR1353 DISMISSAL	375.00
STEVEN MICHAEL TODD	73851	A	424TH CASE #1727	425.00
DEPARTMENT TOTAL				8,505.00
0455-COMMUNITY SERVICES				
JOHNSON CITY SIGN SHOP	73900	A	INV#6385 HHW EVENT	366.00
TEXAS WILDLIFE DAMAGE MGMT FUND	73958	A	AUGUST 2020	2,400.00
DEPARTMENT TOTAL				2,766.00
0460-STATE AGENIES SERVICES				
FRONTIER COMMUNICATIONS	73830	A	830-868-4008 ADULT PROBATION	441.10
DEPARTMENT TOTAL				441.10
0500-COURTHOUSE EXPENSES				
A T & T MOBILITY	73959	A	ACCT #111067935663 CONSTABLE #1	66.55
BLANCO COUNTY APPRAISAL DIST	73824	A	4TH QUARTER PAYMENT	36,212.48
CARD SERVICE CENTER	73944	A	4707 1205 3610 0344 BLANCO COUNTY	7.85
CARD SERVICE CENTER	73948	A	4707 1205 3610 0617 SWIFT	95.79
CITY ELECTRIC SUPPLY COMPANY	73876	A	REF#085296	59.26
CITY ELECTRIC SUPPLY COMPANY	73877	A	REF#066937	139.48
CITY OF BLANCO	73829	A	ACCT 16 SOUTH ANNEX	129.55
CITY OF JOHNSON CITY	73852	A	ACCT #24001-0010007300 COURTHOUSE	183.11
CITY OF JOHNSON CITY	73853	A	ACCT #24001-0010009500 OLD JAIL	75.19
CITY OF JOHNSON CITY	73854	A	ACCT #24001-0010108900 PCT 2	75.19
CITY OF JOHNSON CITY	73855	A	ACCT #24001-0010118600 ANNEX LO	75.19
CITY OF JOHNSON CITY	73856	A	ACCT #24001-0010118700 ANNEX HIGH	37.37
GRAVES HUMPHRIES, STAHL, LIMITED	73832	A	REPORT #COL005 JP 1	990.40
GRAVES HUMPHRIES, STAHL, LIMITED	73864	A	REPORT #COL005 JP 4	687.26
HILL COUNTRY IT	73833	A	INV #489	7,600.00
HILL COUNTRY IT	73894	A	INV#486	600.00
HILL COUNTRY WIRELESS & TECHNOLOGY	73834	A	ACCT #1040	25.00
JOHNSON CITY HYDRO GAS	73895	A	INV#3584 LEC	438.61
JOHNSON CITY PUBLICATIONS LP	73896	A	notice of salary increase	180.00
JOHNSON CITY PUBLICATIONS LP	73897	A	tax increase ad	350.00
JOHNSON CITY PUBLICATIONS LP	73898	A	ROCKIN J REPLAT	71.25
JOHNSON CONTROLS	73901	A	INV#86982023 LEC	1,715.99
LIESMANN MOWING	73903	A	INV#30084584 CH, N.ANNEX	250.00
LOWER COLORADO RIVER AUTHORITY	73835	A	INV #TWER0005782 SEPT.	276.73
LOWER COLORADO RIVER AUTHORITY	73836	A	INV #TWER0005774 OCT.	268.67
OFFICESUPPLY.COM	73913	A	INV#4020074 LEC	269.94
PURCHASE POWER	73840	A	ACCT #80000-9090-0697-9400	2,000.00

TIME:02:03 PM

PREPARER:0004

DEPARTMENT

NAME-OF-VENDOR	INVOICE-NO	S	DESCRIPTION-OF-INVOICE	AMOUNT
SCTI-TELECOM	73927	A	INV#15365 N. ANNEX	345.00
SERVICE LIGHTING & ELECTRICAL SUPPL	73928	A	INV# W022980078 LEC	37.63
TEXAS ASSOCIATION OF COUNTIES	73932	A	P. GRANBERG CONF REGISTRATION	225.00
TEXAS PROPERTY MEDIC LLC	73933	A	INV#1692 OLD JAIL	7,579.42
THYSSENKRUPP ELEVATOR CORPORATION	73849	A	INV # 3005456138	285.76
TIME WARNER CABLE	73843	A	INV #0144415082620 COURTHOUSE	580.00
VERTICAL BRIDGE S3 ASSETS, LLC	73846	A	INV #00125081	637.60
DEPARTMENT TOTAL				62,571.27
0515-JUSTICE OF THE PEACE PCT #1				
BUSINESS CENTER PRINT & OS	73873	A	INV#141661 JP1	252.71
NORTHEAST TEXAS DATA CORP.	73839	A	REPORT #CAS017 JP 1	18.00
POSTMASTER/BOX RENT	73924	A	BOX #405 RENTAL JP1	64.00
DEPARTMENT TOTAL				334.71
0520-JUSTICE OF THE PEACE #4				
NORTHEAST TEXAS DATA CORP.	73865	A	REPORT #CAS017 JP 4	20.00
DEPARTMENT TOTAL				20.00
0525-CONSTABLE PCT #1				
FUELMAN	73937	A	FUEL - CONSTABLE 1	297.78
DEPARTMENT TOTAL				297.78
0530-CONSTABLE PCT #4				
FUELMAN	73938	A	FUEL - CONSTABLE 4	30.42
DEPARTMENT TOTAL				30.42
0550-RECYCLING COORDINATOR				
BLANCO HYDRO GAS CO.	73870	A	ACCT#2411 RECYCLING	14.00
DEPARTMENT TOTAL				14.00
0560-GENERAL FUND CAPITAL EQUIPMENT				
GT DISTRIBUTORS, INC	73892	A	INV#0781010 LEC	2,454.21
GT DISTRIBUTORS, INC	73893	A	INV#0781689 LEC	750.22
RAYMOND C BENOIST	73925	A	2020 FORD FPI INSTALLATION	1,980.50
DEPARTMENT TOTAL				5,184.93
0585-COUNTY INSPECTOR				
CARD SERVICE CENTER	73946	A	4707 1205 3610 0559 ROEDER	50.00
FUELMAN	73939	A	FUEL - INSPECTOR	43.98
DEPARTMENT TOTAL				93.98
FUND TOTAL				102,750.78

TIME:02:03 PM

PREPARER:0004

DEPARTMENT	NAME-OF-VENDOR	INVOICE-NO	S	DESCRIPTION-OF-INVOICE	AMOUNT
0540-R&B PCT #1					
	BRAUNTEX MATERIALS, INC.	73871	A	INV#112657 PCT 1	1,971.84
	CENTRAL TEXAS EXCAVATION, INC.	73875	A	INV#3496 PCT 1	7,020.00
	DAD SERVICES, INC	73879	A	INV#200816 PCT 1	500.00
	DAD SERVICES, INC	73880	A	INV#200833 PCT 1	450.00
	DAD SERVICES, INC	73881	A	INV#200834 PCT 1	7,500.00
	FUELMAN	73940	A	FUEL PCT 1	614.92
	KIRK FELPS	73902	A	INV#82320 PCT 1	12.95
	N GLANTZ & SON	73904	A	ORDER #6613137-00 PCT 1	197.79
	OFFICE TIME SAVERS, INC.	73915	A	INV#16261 PCT 1	42.50
	SEYMOURS INC.	73929	A	INV#45024 PCT 4	405.07
	DEPARTMENT TOTAL				18,715.07
0550-R&B PCT #2					
	ARMADILLO MATERIALS LLC	73869	A	INV#0008542-IN PCT 2	980.42
	CARD SERVICE CENTER	73949	A	4707 1205 3610 0617 SWIFT	549.99
	EMIL UECKER	73882	A	REIMBURSEMENT	36.30
	EMIL UECKER	73883	A	REIMBURSEMENT	409.08
	FUELMAN	73941	A	FUEL - PCT 2	667.88
	N GLANTZ & SON	73905	A	ORDER #6613137-00 PCT 2	197.79
	OFFICE TIME SAVERS, INC.	73916	A	INV#16261 PCT 2	42.50
	PETERSON TIRE	73923	A	INV#JC33551 PCT 2	41.45
	DEPARTMENT TOTAL				2,925.41
0560-R&B PCT #3					
	ADVANCE REPAIR SOLUTIONS	73867	A	REPAIRS OF MACK TRUCK	129.00
	CARD SERVICE CENTER	73945	A	4707 1205 3610 0385 LIESMANN	75.86
	CONSTRUCTION EDGE	73878	A	INV#10665 PCT 3	404.50
	ERGON ASPHALT AND EMULSIONS, INC	73884	A	INV#9402325523 PCT 3	2,231.34
	FORD & CREW HOME AND HARDWARE	73887	A	TRANS#A175217 PCT 3	119.98
	FORD & CREW HOME AND HARDWARE	73888	A	TRANS#A174129 PCT 3	291.55
	N GLANTZ & SON	73906	A	ORDER #6613137-00 PCT 3	197.79
	ODIORNE FEED/RANCH SUPPLY INC	73912	A	INV#164536 PECT 3	79.00
	OFFICE TIME SAVERS, INC.	73917	A	INV#16261 PCT 3	42.50
	THIRD COAST DISTRIBUTING, LLC	73936	A	INV#039410 PCT 3	28.18
	DEPARTMENT TOTAL				3,599.70
0570-R&B PCT #4					
	FUELMAN	73942	A	FUEL - PCT 4	794.62
	JOHNSON CITY SIGN SHOP	73899	A	INV#6386 PCT 4	250.00
	N GLANTZ & SON	73907	A	ORDER #6613137-00 PCT 4	197.79
	OFFICE TIME SAVERS, INC.	73918	A	INV#16261 PCT 4	42.50
	PETERSON TIRE	73921	A	INV#BL41046 PCT 4	356.90
	PETERSON TIRE	73922	A	INV#BL41173 PCT 4	834.00
	THIRD COAST DISTRIBUTING, LLC	73934	A	INV#818803 PCT 4	83.84
	THIRD COAST DISTRIBUTING, LLC	73935	A	INV#820132 PCT 4	152.00
	DEPARTMENT TOTAL				2,721.65
	FUND TOTAL				27,951.83

 DEPARTMENT

NAME-OF-VENDOR	INVOICE-NO	S	DESCRIPTION-OF-INVOICE	AMOUNT
0400-CHILD SAFETY FUND EXPENSES				
BLANCO CO CHILD PROTECTION BD	73860	A	REIMBURSEMENT	5,018.88
DEPARTMENT TOTAL				5,018.88
FUND TOTAL				5,018.88

DEPARTMENT				
NAME-OF-VENDOR	INVOICE-NO	S	DESCRIPTION-OF-INVOICE	AMOUNT
0400-RECORDS MANAGEMENT DISTRICT EXPENCE				
NORTHEAST TEXAS DATA CORP.	73909	A	INV#ND-001881	734.07
DEPARTMENT TOTAL				734.07
FUND TOTAL				734.07

DEPARTMENT				
NAME-OF-VENDOR	INVOICE-NO	S	DESCRIPTION-OF-INVOICE	AMOUNT
0400-EXPENSES				
NORTHEAST TEXAS DATA CORP.	73908	A	INV#ND-001881	1,000.00
DEPARTMENT TOTAL				1,000.00
FUND TOTAL				1,000.00

DEPARTMENT				
NAME-OF-VENDOR	INVOICE-NO	S	DESCRIPTION-OF-INVOICE	AMOUNT
0400-EXPENSES				
RUVALCABAS PAVING CO	73926	A	middle creek rd paving	50,000.00
DEPARTMENT TOTAL				50,000.00
FUND TOTAL				50,000.00

DEPARTMENT	NAME-OF-VENDOR	INVOICE-NO	S	DESCRIPTION-OF-INVOICE	AMOUNT
0400-INTEREST & SINKING EXPENSES	BROADWAY BANK	73826	A	LOAN #1755110000	5,702.25
	DEPARTMENT TOTAL				5,702.25
	FUND TOTAL				5,702.25

DEPARTMENT

NAME-OF-VENDOR

INVOICE-NO

S

DESCRIPTION-OF-INVOICE

AMOUNT

GRAND TOTAL

193,157.81



APPOINTMENT FORM - GENERAL ASSEMBLY REPRESENTATIVE CAPITAL AREA COUNCIL OF GOVERNMENTS

The governing bodies of CAPCOG's members designate General Assembly representatives.

Counties: Official appointments are made at Commissioners Court.
Cities, Towns, Villages: Official appointments are made at City Council meetings.
Organizations: Official appointments are made by the Board or other governing body.

PLEASE COMPLETE THE FOLLOWING SECTION

Governing Body:

Blanco County Commissioners Court (e.g., Travis County Commissioners Court)
-OR-
_____ City Council (e.g., Austin City Council)
-OR-
_____ Other (Board or other governing body)

COPY

Blanco County
City, County, or Organization being represented

Brett Bray
Name of Representative

Blanco County Judge
Position

PO Box 387
Address

Johnson City, TX 78636-0387
City, Zip Code

830-868-4266
Telephone Number

830-868-9112
Fax Number

cojudge@co.blanco.tx.us
Email address (General Assembly Reps. will be subscribed to CAPCOG Connections, Training Alerts, & other e-newsletters.)

Check One:

- Reappointment
- Filling Vacancy
- Changing Representative

Name of Previous Representative

I confirm our governing body appointed the above individual to serve as a CAPCOG General Assembly Representative for the above entity on September 8, 2020.
Date of Meeting

Signature of Chief Elected Official/Chair of Governing Board

Date

Please fax this form to 512-916-6001 or email it to dbrea@capcog.org. For questions about completing this form, call Deborah Brea at 512-916-6018.

RESOLUTION

EARLY VOTING SCHEDULE

RESOLUTION AUTHORIZING AND ESTABLISHING THE MAIN EARLY VOTING POLLING SITE FOR THE **NOVEMBER 5, 2019 SPECIAL CONSTITUTIONAL AMENDMENT ELECTION** PURSUANT TO CHAPTER 85, TEXAS ELECTION CODE.

WHEREAS the provisions of Chapter 85, Texas Election Code, were enacted to maximize the opportunity for all of the people to exercise the right to vote; and

WHEREAS the **COMMISSIONERS COURT OF BLANCO COUNTY** desires to establish the main polling places for the early voting period which will run from Tuesday, October 13st through Friday, October 30th for the **NOVEMBER 3, 2020 JOINT GENERAL ELECTION** in accordance with Chapter 85, Texas Election Code; and

WHEREAS the **COMMISSIONERS COURT OF BLANCO COUNTY** believes that the processes of our government work best when the people participate in the electoral process; therefore

BE IT RESOLVED by the **COMMISSIONERS COURT OF BLANCO COUNTY** that in order to maximize access to the polls, the following early voting site is approved and established for the early voting period of the **NOVEMBER 3, 2020 JOINT GENERAL ELECTION**:

SECTION 1. MAIN EARLY VOTING SITE. The main early voting site required under Section 85.002 (b), 85.005 (c), and 85.006 (e), Texas Election Code, shall be established as follows:

Blanco County Courthouse Annex – Hoppe Room, 101 E. Cypress – Johnson City, TX
(Edificio Anexo de la Corte del Condado de Blanco – Cuarto Hoppe)

Tuesday,	October 13	thru	October 16	8:00 am - 4:30 pm
Monday,	October 19	thru	October 23	8:00 am - 4:30 pm
Saturday,	October 24			8:00 am - 4:30 pm
Sunday,	October 25			10:00 am - 2:00 pm
Monday,	October 26	thru	October 30	8:00 am - 4:30 pm

Blanco County South Annex, 402 Blanco Ave – Blanco, TX
(Anexo Sur del Condado de Blanco)

Tuesday,	October 13	thru	October 16	8:00 am - 4:30 pm
Monday,	October 19	thru	October 23	8:00 am - 4:30 pm
Saturday,	October 24			8:00 am - 4:30 pm
Sunday,	October 25			10:00 am - 2:00 pm
Monday,	October 26	thru	October 30	8:00 am - 4:30 pm

APPROVED AND PASSED this 8th day of September, 2020.

Hon. Brett Bray
Blanco County Judge

COPY

Hon. Tommy Weir
County Commissioner, Precinct 1

Hon. Emil Ray Uecker
County Commissioner, Precinct 2

Hon. Chris Liesmann
County Commissioner, Precinct 3

Hon. Paul Granberg
County Commissioner, Precinct 4

Attest:

Hon. Laura Walla
County Clerk

RESOLUTION

ELECTION DAY SITES

AUTHORIZING AND ESTABLISHING ELECTION DAY POLLING SITES FOR THE **NOVEMBER 3, 2020 SPECIAL CONSTITUTIONAL AMENDMENT ELECTION**, PURSUANT TO CHAPTER 43 AND SECTION 42.008 (a), TEXAS ELECTION CODE.

WHEREAS the provisions of Chapter 43, Texas Election Code, were enacted to maximize the opportunity for all of the people to exercise their right to vote; and

WHEREAS the **COMMISSIONERS COURT OF BLANCO COUNTY** desires to establish polling places in accordance with Chapter 43, Texas Election Code; and

WHEREAS the **COMMISSIONERS COURT OF BLANCO COUNTY** believes that the processes of government work best when the people participate in the electoral process; and

WHEREAS Section 42.008 (a), Texas Election Code, allows a Commissioners Court to consolidate two or more election precincts into a single precinct so long as the polling places are located so that the voters of those consolidated precincts will be adequately served;

THEREFORE, BE IT RESOLVED by the **COMMISSIONERS COURT OF BLANCO COUNTY** that the polling places as listed below are established and approved for the **November 3, 2020 Special Constitutional Amendment Election**, pursuant to Chapter 43 and Section 42.008 (a), Texas Election Code, as follows:

<u>Pct</u>	<u>Location</u>	<u>Address</u>	<u>City</u>
102	First Baptist Church	1200 4th Street	Blanco
201	Good Shepherd Catholic Church	285 281 Loop	Johnson City
302	Blanco County Annex - Hoppe Room	101 E. Cypress Street	Johnson City
303	Blanco County Commission Pct 3 Barn	862 Ranch Road 962 E	Round Mountain
304	St. Lukes Episcopal Church - Parish Hall	263 Spur 962	Cypress Mill
401	Blanco County South Annex	402 Blanco Ave	Blanco

APPROVED AND PASSED this 8th day of September, 2020.

Hon. Brett Bray
Blanco County Judge

Hon. Tommy Weir
County Commissioner, Precinct 1

Hon. Emil Ray Uecker
County Commissioner, Precinct 2

Hon. Chris Liesmann
County Commissioner, Precinct 3

Hon. Paul Granberg
County Commissioner, Precinct 4

Attest:

Hon. Laura Walla
County Clerk

ORDER OF APPOINTMENT OF ELECTION
ALTERNATE JUDGE TO A TWO-YEAR (UNEXPIRED) TERM
SUPPLEMENTAL LIST

The Commissioners Court of Blanco County does hereby appoint the following election alternate presiding judge to the Early Voting Ballot Board (EVBB) to the unexpired term of the alternated judge that had previously been appointed to serve a two-year term from September 1, 2019 and terminate August 31, 2021, pursuant to Sec. 320.002(e), Texas Election Code.

Prec	Location	Address	Alternate Presiding Judge
EVBB	Blanco County Courthouse Annex - Conference Room	101 E. Cypress Street	Jett Sophia

It is hereby directed that this order be filed with the clerk of this court and that a copy be provided to the custodian of the election records for Blanco County.

The Elections Administrator is here by instructed to send a notice of appointment to the alternate presiding judge notifying her of the appointment in accordance with Section 32.009, Texas Election Code.

APPROVED AND PASSED this 8th day of **September 2020**.

Hon. Brett Bray
Blanco County Judge

Hon. Tommy Wier
County Commissioner Pct. 1

Hon. Emil Ray Uecker
County Commissioner Pct. 2

Hon. Chris Liesmann
County Commissioner Pct. 3

Hon. Paul Granberg
County Commissioner Pct. 4

Attest:

Hon. Laura Walla
Blanco County Clerk

COPY



CONTRACT PRICING WORKSHEET
For MOTOR VEHICLES Only

Contract No.:

BT01-19

Date Prepared:

8/20/2020

This Worksheet is prepared by Contractor and given to End User. If a PO is issued, both documents MUST be faxed to H-GAC @ 713-993-4548. Therefore please type or print legibly.

Buying Agency:	Blanco County Sheriff's Office	Contractor:	Creative Bus Sales, Inc.
Contact Person:	Neal Leonard	Prepared By:	Casey Gaskins
Phone:	830-868-7104	Phone:	469-333-8909
Fax:	830-868-9311	Fax:	469-333-8918
Email:	nleonard@co.blanco.tx.us	Email:	CaseyG@creativebussales.com

Product Code:	FFGA	Description:	Ford Transit 350 12 Passenger
---------------	------	--------------	-------------------------------

A. Product Item Base Unit Price Per Contractor's H-GAC Contract: 45781

B. Published Options - Itemize below - Attach additional sheet(s) if necessary - Include Option Code in description if applicable.
(Note: Published Options are options which were submitted and priced in Contractor's bid.)

Description	Cost	Description	Cost
CB13-001 FRP ON CEILING	448.8		
CB01-003 HEAVY DUTY DRIVER RUNNING BOARD	374		
CB03-006 INTERIOR LED DOME LIGHTS	224.4		
CB06-015 A/C UPGRADE	3291.22		
CB06-052 COOLANT BOOSTER PUMP	344.08		
CBS-GP7 Interior/Exterior Camera System w/ 3 Cameras & M	4331.25		
		Subtotal From Additional Sheet(s):	0
		Subtotal B:	9013.75

C. Unpublished Options - Itemize below / attach additional sheet(s) if necessary.
(Note: Unpublished options are items which were not submitted and priced in Contractor's bid.)

Description	Cost	Description	Cost
BULKHEAD W/ DOOR ACCESS	1523	CARGO WINDOW SCREEN KIT	1382
BULKHEAD ASSEMBLY	1249	Subtotal From Additional Sheet(s):	3675
REAR SLIDER - EXPANDED W/ CITI SEAT UPGRADE	2554	Subtotal C:	10383

Check: Total cost of Unpublished Options (C) cannot exceed 25% of the total of the Base Unit Price plus Published Options (A+B). **For this transaction the percentage is:** 19%

D. Total Cost Before Any Applicable Trade-In / Other Allowances / Discounts (A+B+C)

Quantity Ordered:	1	X Subtotal of A + B + C:	65177.75	=	Subtotal D:	65177.75
-------------------	---	--------------------------	----------	---	--------------------	----------

E. H-GAC Order Processing Charge (Amount Per Current Policy) **Subtotal E:** 600

F. Trade-Ins / Special Discounts / Other Allowances / Freight / Installation / Miscellaneous Charges

Description	Cost	Description	Cost
PDI & MAKE READY	750	Freight to Johnson City, TX	425
Bus Door/250/Camera Credit	-2423.28	Installation	1086
Camera System Install	764	Subtotal F:	601.72

Delivery Date: 90 Days From PO **G. Total Purchase Price (D+E+F):** 66379.47



8/25/2020

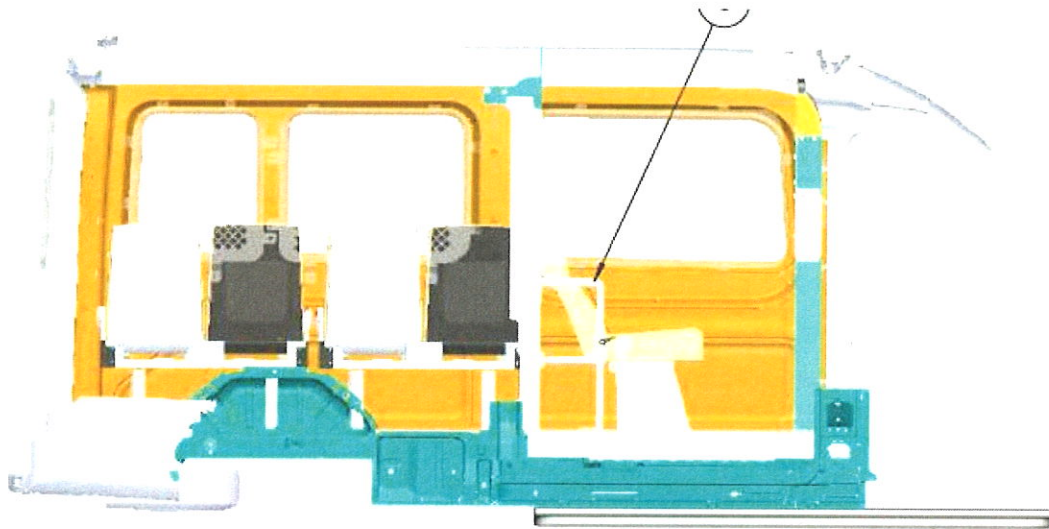
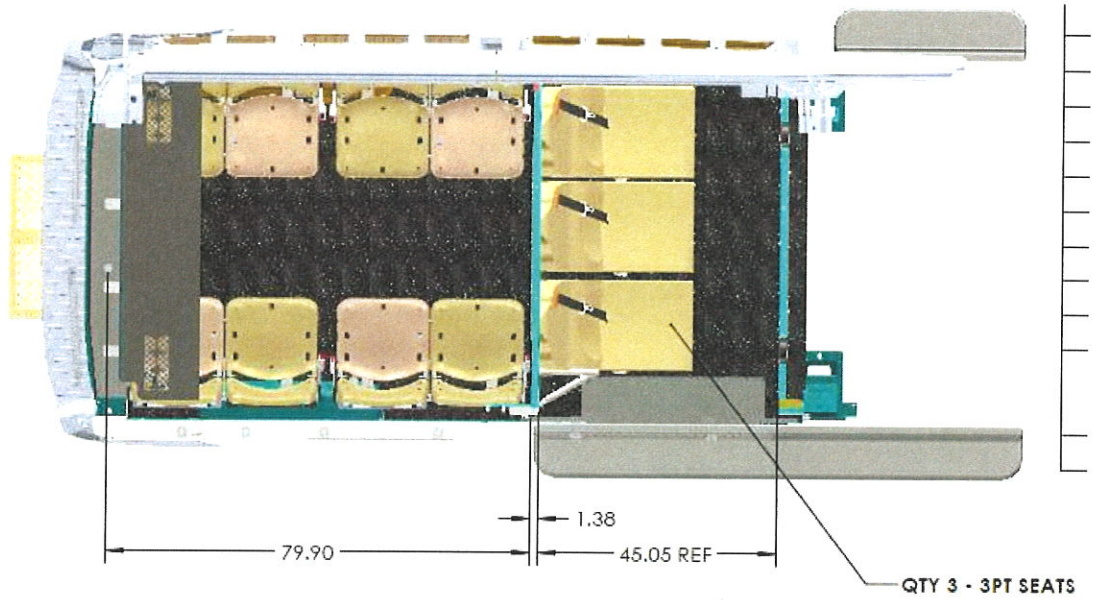



DESCRIPTION	QTY.
SIDE THRESHOLD CONVICT	1
REAR THRESHOLD - TW WALLS	1
#1 BULKHEAD w/ DOOR ACCESS	1
#2 BULKHEAD ASSY	1
REAR SLIDER - EXPANDED	1
C GRAB	1
CARGO WINDOW SCREEN KIT	1
RR AC / HEAT - TW WALLS	1
.75 DIA X .50 THK X .38 I.S. SPACER	2
5/16-18 PLUSNUT	2
FAN - 12V	2

NOTES:

- ABS INTERIOR WITH HEADLINER - TW STANDARD
- 3 GUARD POSITIONS AND 8 PRISONERS
- PRIMARY BULKHEAD with ESCAPE HATCH INTO CAB
- SECONDARY BULKHEAD - NO PASS-THROUGH
- REAR OVERHEAD AC/ HEAT WITH COVER
- REAR SLIDING STEP
- FULL PASS STEP- BLACK
- SHORT DRIVER STEP - BLACK
- STEEL THRESHOLDS - SIDE AND REAR
- 6 DOME LIGHTS INSTALLED - OPERATES WITH OEM
- WINDOW SCREENS INSTALLED ON ALL WINDOWS
- PLYWOOD FLOOR WITH ALTRO COVERING - BLACK
- STEEL OVERLAY SUB-FLOOR

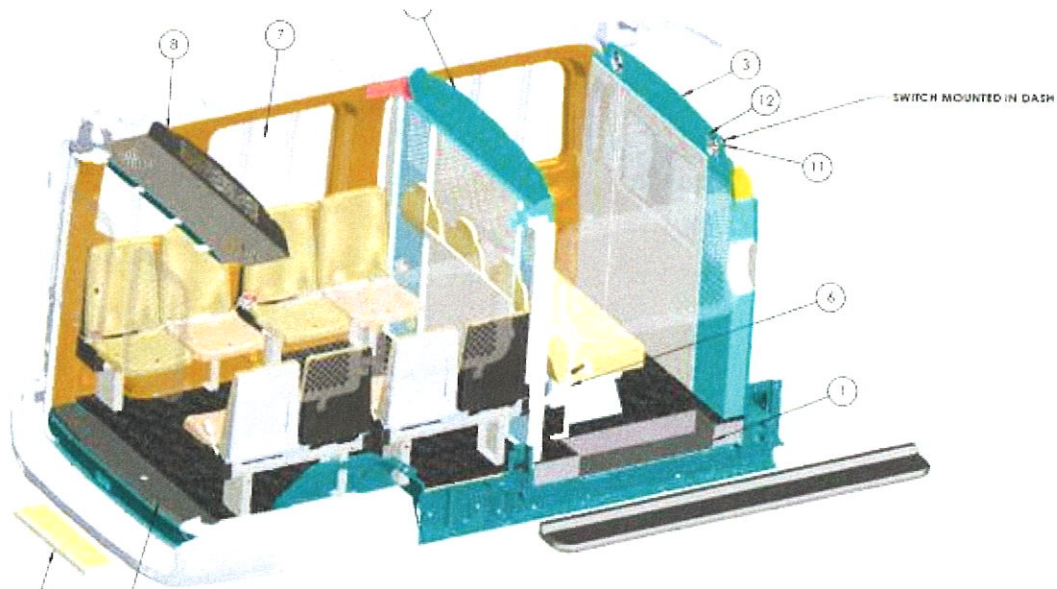

Prison Upfit/Conversion:

TWO COMPARTMENTS 11 PASSENGER PRISON TRANSPORT VAN PACKAGE
TW ABS INTERIOR AND HEADLINER
#1 BULKHEAD W/ DOOR ACCESS
#2 BULKHEAD ASSEMBLY
REAR SLIDER-EXPANDED
9.5" EXPANDED METAL STEEL REAR SLIDE OUT STEP
C GRAB RAIL
CARGO WINDOW SCREEN KIT
2 PASSENGER CITI SEATS (4)
FREEDMAN 3PT GRAY VINYL SEATS IN CENTER SECTION
FULL PASSENGER SIDE RUNNING BOARD
DRIVER FRONT DOOR STEP
STEEL OVERLAY SUB FLOOR
LED DOME LIGHTS - OPERATES WITH OEM (6)
ALTRO VINYL FLOORING - BLACK PLYWOOD SUB FLOORING
TWIN AIR 25K BTU SERIES 5 OVERHEAD AC/HEAT SYSTEM
ADD ON COOLANT PUMP



Creative Bus Sales

CHASSIS:

2020 FORD TRANSIT 250 MR VAN
148" WB
OXFORD WHITE
3.5L V6 GAS ENGINE
10 SPEED AUTOMATIC TRANSMISSION
9,000 LB GVWR
REAR WINDOWS MAXIMUM TINT

ADDITIONAL OPTIONS:

CAMERA SYSTEM

- 3 CAMERAS (INTERIOR)
- 500 GB HARD DRIVE
- 7" WIDE LCD MONITOR IN PASSENGER AREA
- INSTALLATION

FRONT BRUSH GUARD

FRONT AND REAR EMERGENCY LIGHTS

SIREN

2 WAY RADIO INSTALL



Quote Number: QU0000512139
Effective: 26 AUG 2020
Effective To: 25 OCT 2020

Bill-To:
BLANCO COUNTY
PO BOX 471
JOHNSON CITY, TX 78636
United States

Ultimate Destination:
BLANCO COUNTY
400 S HWY 281
JOHNSON CITY, TX 78636
United States

Attention:
Name: ROBERT WOODRING
Email: RWOODRING@CO.BLANCO.TX.US
Phone: 830-868-7104

Sales Contact:
Name: Ted Lynch
Email: ted.lynch@bearcom.com
Phone: 512-289-1835

Request For Quote: APX6500 REMOTE MOUNT
Contract Number: HGAC
Freight terms: FOB Destination
Payment terms: Net 30 Due

Item	Quantity	Nomenclature	Description	List price	Your price	Extended Price
l	1	M25KSS9PW1BN	APX6500 ENHANCED VHF	\$2,738.00	\$1,998.74	\$1,998.74
la	1	B18CR	ADD: AUXILIARY SPKR 7.5 WATT	\$60.00	\$43.80	\$43.80
lb	1	G299AE	ADD: 1/4 WAVE ROOF TOP 150.8-162	\$19.50	\$14.24	\$14.24
lc	1	GA00580AA	ADD: TDMA OPERATION APX	\$450.00	\$328.50	\$328.50
ld	1	GA01767AG	APX MOBILE RADIO AUTHENTICATION	\$100.00	\$73.00	\$73.00
le	1	GA00235AA	ADD: NO GPS ANTENNA NEEDED	-	-	-
lf	1	G444AH	ADD: APX CONTROL HEAD SOFTWARE	-	-	-
lg	1	GA01670AA	ADD: APX E5 CONTROL HEAD	\$572.00	\$417.56	\$417.56
lh	1	G628AC	ADD: REMOTE MOUNT CBL 17 FEET	\$15.00	\$10.95	\$10.95
li	1	QA01648AA	ADD: ADVANCED SYSTEM KEY - HARDWARE KEY	\$5.00	\$3.65	\$3.65
lj	1	W22BA	ADD: STD PALM MICROPHONE APX	\$72.00	\$52.56	\$52.56
lk	1	G67DT	ADD: REMOTE MOUNT E5 APXM	\$297.00	\$216.81	\$216.81
ll	1	G78AT	ADD: 3Y ESSENTIAL SERVICE	\$168.00	\$168.00	\$168.00
lm	1	G361AH	ENH: P25 TRUNKING SOFTWARE APX	\$300.00	\$219.00	\$219.00
ln	1	G51AU	ENH: SMARTZONE OPERATION APX6500	\$1,200.00	\$876.00	\$876.00
lo	1	G806BL	ENH: ASTRO DIGITAL CAI OP APX	\$515.00	\$375.95	\$375.95

Total Quote in USD

\$4,798.76

PO Issued to Motorola Solutions Inc. must:
>Be a valid Purchase Order (PO)/Contract/Notice to Proceed on Company Letterhead. Note: Purchase Requisitions cannot be accepted
>Have a PO Number/Contract Number & Date
>Identify "Motorola Solutions Inc." as the Vendor
>Have Payment Terms or Contract Number
>Be issued in the Legal Entity's Name
>Include a Bill-To Address with a Contact Name and Phone Number
>Include a Ship-To Address with a Contact Name and Phone Number



TEXAS DEPARTMENT OF AGRICULTURE
TEXANS FEEDING TEXANS: HOME-DELIVERED MEALS
GRANT PROGRAM

RESOLUTION AUTHORIZING COUNTY GRANT
PROGRAM YEAR 2021

A resolution of the County of Blanco (County), Texas, certifying that the county has made a grant to Meals on Wheels of the RCA/Combined Community Action (Organization), an organization that provides home-delivered meals to homebound persons in the county who are elderly and/or have a disability, and certifying that the county has approved the organization's accounting system or fiscal agent.

WHEREAS, the Organization desires to apply for grant funds from the Texas Department of Agriculture to supplement and extend existing services for homebound persons in the County who are elderly and/or have a disability, pursuant to the Home-Delivered Meals Grant Program (Program); and

WHEREAS, the Program rules require the County in which an Organization is providing home-delivered meal services to make a grant to the Organization, in order for the Organization to be eligible to receive Program grant funds; and

WHEREAS, the Program rules require the County to approve the Organization's accounting system or fiscal agent, in order for the Organization to be eligible to receive Program grant funds; and

WHEREAS, the County recognizes Kelly Franke, Executive Director (Authorized Official) as an official of the Organization applying for a Home-Delivered Meal Grant from the Texas Department of Agriculture.

BE IT RESOLVED BY THE COUNTY:

SECTION 1: The County hereby certifies that it has made a grant to the Organization in the amount of \$5000.00 to be used between the:

1 of October 2020 and the 30 of September 2021
Day Month Year Day Month Year

SECTION 2: The County hereby certifies that the Organization provides home-delivered meals to homebound persons in the County who are elderly and/or have a disability.

SECTION 3: The County hereby certifies that it has approved the Organization's accounting system or fiscal agent which meets financial management system requirements as set forth in the Uniform Grant Management Standards promulgated by the Texas Comptroller of Public Accounts.

Introduced, read, and passed by the affirmative vote of the County on this 8 day of September, 2020

Signature of Authorized Official of the County
Brett Bray, Blanco County Judge
Typed Name and Title

NOTE: All information shown in this resolution must be included in the resolution passed by the County.
Updated May 2020

ORDER DESIGNATING DAY OF THE WEEK ON WHICH COURT SHALL CONVENE

WHEREAS, Section 81.005(a) of the Texas Local Government Codes states that the County Commissioners Court by order shall designate a day of the week on which the court shall convene in a regular term each month; and

WHEREAS, on September 8, 2020, the Blanco County Commissioners Court by a vote of _____ YAYS, _____ NAYS, _____ ABSTAIN, _____ ABSENT, elected to hold the regular meeting on the second Tuesday of each month beginning at 9:00 a.m.

NOW, THEREFORE BE IT RESOLVED by the Blanco County Commissioners Court that the following are made to said vote on September 8, 2020:

1. The meetings shall be held in the Commissioners Courtroom located in the Blanco County Courthouse located at 101 E Pecan Dr, Johnson City, Blanco County, Texas.
2. The original agenda shall be posted on the East entrance door of the aforesaid County Courthouse and posted on the County website in accordance with Section 551.043 of the Texas Government Code.

ORDERED, PASSED, ENACTED, ADOPTED AND APPROVED on the 8th day of September 2020.

SIGNED on the 8th day of September 2020.

The Commissioners Court of Blanco County, Texas

Brett Bray, Blanco County Judge

Tommy Weir, Commissioner Precinct 1

Emil Uecker, Commissioner Precinct 2

Chris Liesmann, Commissioner Precinct 3

Paul Granberg, Commissioner Precinct 4

ATTEST:

Laura Walla, Blanco County Clerk

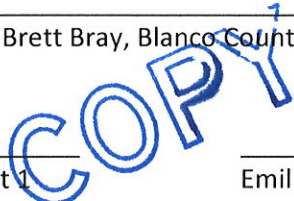

before

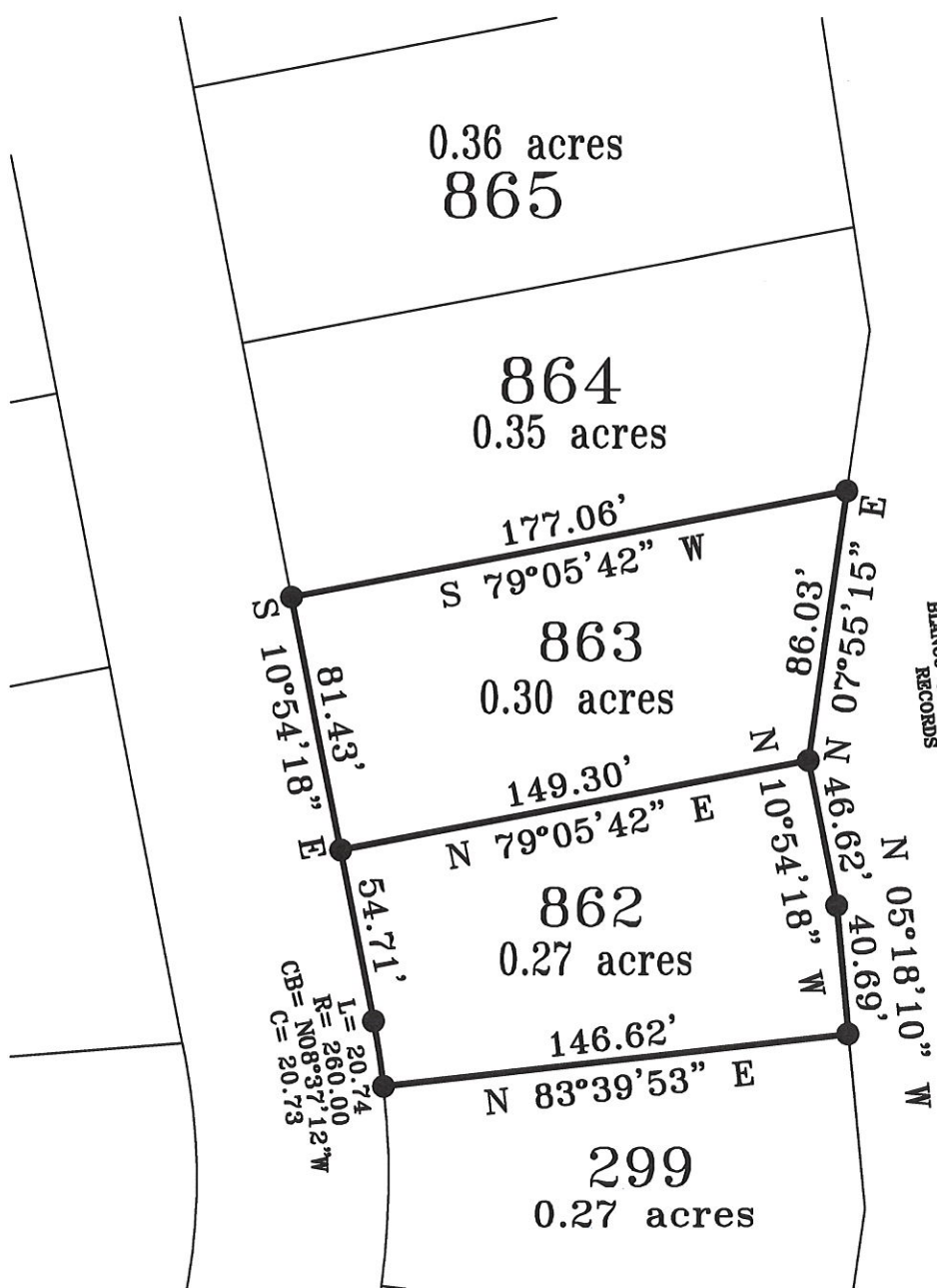

ROCKING J RANCH, LTD.
CALLED 1064.80 ACRE
TRACT AS RECORDED IN
VOLUME 284, PAGE 949,
BLANCO COUNTY DEED
RECORDS

VACATE

LOT 862 AND 863
ROCKIN J RANCH, UNIT 3, AS RECORDED
IN VOL. 1, PAGES 378-390, OF THE MAP AND PLAT
RECORDS OF BLANCO COUNTY, TEXAS.
SCALE: 1" = 60'

0 ft.

After

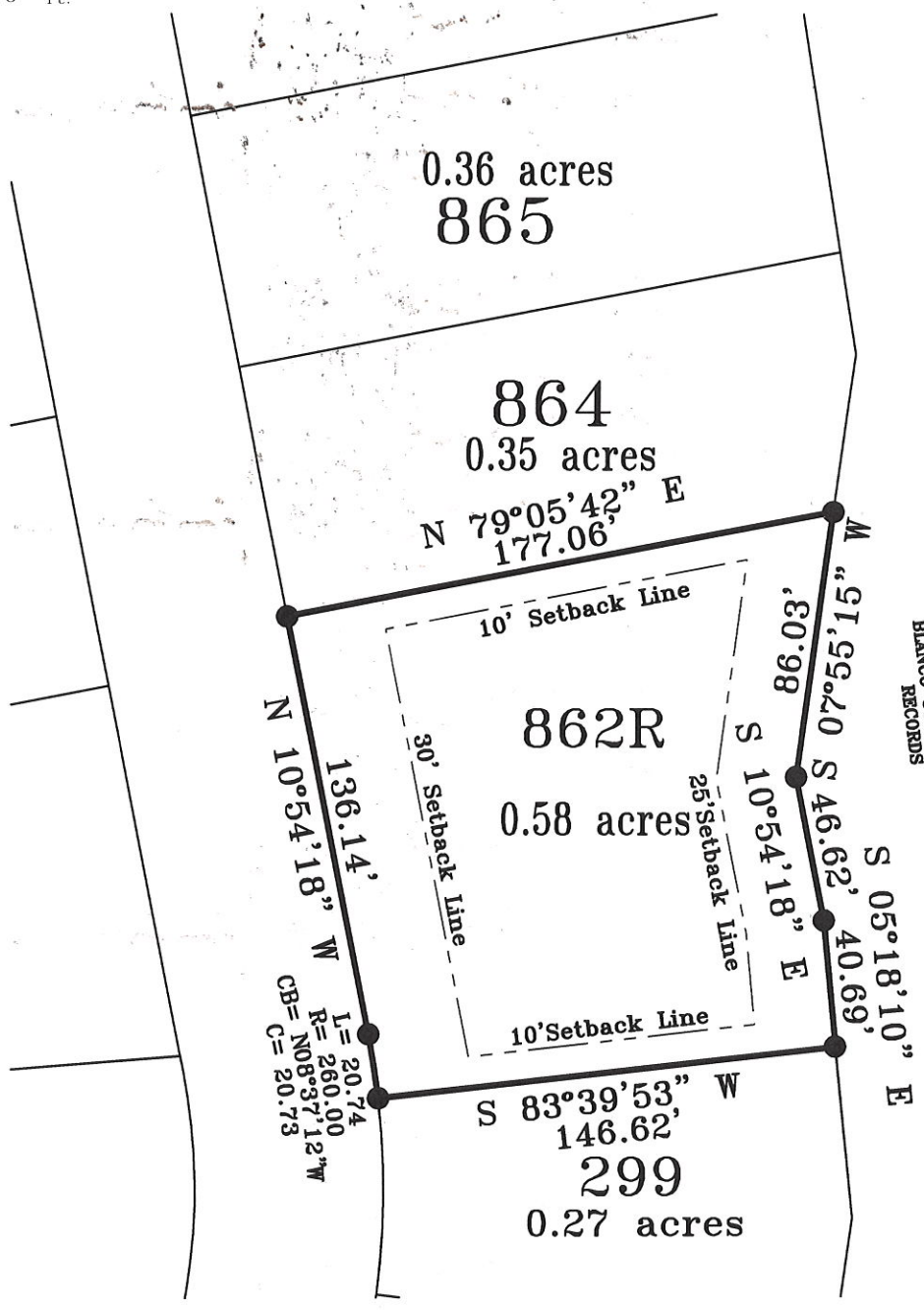

ROCKING J RANCH, LTD.
CALLED 1064.80 ACRE
TRACT AS RECORDED IN
VOLUME 284, PAGE 949,
BLANCO COUNTY DEED
RECORDS

REPLAT

ESTABLISHING LOT 862R
ROCKIN J RANCH, UNIT 3.

SCALE: 1" = 60'